



MAHARASHTRA STATE ELECTRICITY TRANSMISSION CO. LTD.
(CIN No.U40109MH2005SGC153646)

From:
Office of the Executive Engineer
EHV O&M Division, MSETCL, Mirjole Road,
MIDC, Ratnagiri – 415 639.
Ph. No. 02352 – 231388.
E-mail: ee3220@mahatransco.in
Website: www.mahatransco.in

Ref. No.: EE/EHV O&M DN/RTN/T/ **No.01321**

Date: **27.09.2022**

Enquiry

Sub: Enquiry for Providing of gantry structure for 100MVA, 220/132 kV ICT at 220 kV Kharepatan S/s, under EHV O&M Division, Ratnagiri.

Dear Sir,

Sealed and super scribed quotations are invited for the above work as specification mentioned in schedule 'A'. The quotations giving full particulars should reach this office on or before **04.10.2022** positively.

Terms and Conditions:

- 1) **Prices:** The rates should be quoted for material as per schedule 'A' for work at 220 kV Kharepatan S/s, under EHV O&M Division Ratnagiri.
- 2) **Quoted Rates:** The quoted rates should include the cost of material, fabrication, transportation, loading & unloading charges etc. The taxes applicable if any should be quoted separately.
- 3) **Qualifying conditions:**
 - a) PAN/ TAN registration certificate.
 - b) Valid GST registration certificate.
 - c) Experience Certificate of similar type of work executed in MSETCL/ MSEDCL/ PGCIL or any other Govt./ Semi-Govt. organization from not below the rank of Executive Engineer with detail work order copy.
 - d) Annexure-G
 - e) Approved vendor of MSETCL for manufacturing of gantry & equipment support structures at 220 kV level.
- 4) **Security Deposit:** 10% of the value of order is to be paid as Security Deposit by Cash / D.D./BG at EHV O&M Circle Kolhapur in favor of the Superintending Engineer EHV O&M Circle Kolhapur office within 7 days from the date of intimation by this office. No Interest will be paid on this amount and this will be refunded after completion of contract period satisfactorily & NOC from the concerned In-charge. Extension of validity of SD till over of guarantee period of work executed is sole responsibility of agency.
- 5) **Quality of Supply:** The material should from approved vendor of MSETCL for gantry & equipment support structures at 220 kV level & as per the drawing attached.

6) **Technical Specifications:**

Gantry for 100MVA, 220/132 kV ICT should be supplied as per approved drawing attached.

Beam type – B9 – 1 No.

Column type – T9X – 1 No.

- 7) **Completion period:** Work should be completed within 60 days from the date of the issue of order.
- 8) **Validity of Offer :** The offer should be valid for our acceptance for a period of 90 days from the due date of opening.
- 9) Quantity as per schedule A.
- 10) **Risk Purchase:** In case of failure to execute the order, the same will be purchased from other agency at our description and difference in cost will be recovered from the contractor in addition to forfeiture of S.D.
- 11) **Terms of Payment:** - The bills should be submitted in triplicate to Executive Engineer, EHV O&M Division, Ratnagiri. 100% payment will be made on production of following documents.
a) Invoice b) Delivery Challan, c) Guarantee Certificate, d) S.D. receipt
- After completion of work, In-charge will create PMO within 3 days in SAP through contract only prepared by Division and on the basis of MOM and irrespective of invoice received. PO will be created by Division Office & Service entry, MIGO, material inspection will be made by respective S/s In-charge.
- 12) **Safety:** The contractor should provide all safety equipment required for the work to his workers. Any accident occurs due to non-supply of these equipments or careless handling of equipment the same shall be in the contractor risk & cost. The contractor must maintain first aid box in safe custody.
- 13) **Damage to the person & property:** The contractor shall Indemnity the MSETCL against any loss and claims regarding any injuries or damage to any persons, material and physical damage to any property whatsoever which may arise out or in consequence of the execution of work.
- 14) **Penalty for late delivery:** In case, material is not delivered in stipulated time the contractor shall be liable to pay penalty at ½% per week subject to maximum 10% of the order value.
- 15) **Deduction:** Any amount or amounts which become payable by the contractor to the MSETCL under particular contract may be deducted by the purchaser from any amount / amounts due or becoming due by him to the contract under the same or any other contract.
- 16) **Income Tax:** All the taxes, wages, duties, Cess by whatever may it called in India at prevailing rate will be applicable to this enquiry & as per Govt. rule these taxes at source will be recovered from your bill. Your Income tax No. may be informed to this office.
- 17) **Jurisdiction:** All disputes, differences related to the contract if any, the legal jurisdiction of the court shall be Ratnagiri only.
- 18) **Precaution:** All equipments in switchyard in live condition. The contractor will have to take all precautions at the contractor cost till the completion of work. MSETCL will not responsible for any accident (fatal or non-fatal) or injury to the personnel of the contractor or any financial implication arising there from.
- 19) **Rework:** Any work i.e. to be carried or already executed work found defective due to faulty workmanship or improper execution or material supplied in not as per quality & specification shall be done good by the contractor free of cost, failure to which the work shall be got done by other agency and the cost shall be recovered from the contractor.

- 20) **Guarantee:** You will have to give the guarantee of one year for workmanship & material from the date of work completion and guarantee should be submitted alongwith the bills. For any defects in workmanship/material you will have to give free service within 7 days from the date of intimation within guarantee period.
- 21) Please mentioned PAN No./ GST Registration No. if applicable / PF No. & ESI No. if applicable on the bill otherwise bill will be kept pending.
- 22) Bidders have to submit an undertaking in the attached proforma 'Annexure-G' declaring that their Firm is not Debarred/Blacklisted by Govt./Semi Govt./Other Power Utilities, anywhere.
- 23) You are also deemed to be fully aware of the Company's general conditions of contract for work and any ignorance of any of the conditions will not exempt you from your liability to abide by the same.
- 24) You shall not sub-contract without the prior written permission of the company.

The undersigned reserves the right to reject any or all quotations without assigning any reasons.

Encl: Schedule 'A' & Annex-G

sd/-
(Vijaykumar A. Nikam)
Executive Engineer
EHV O&M Dn., MSETCL,
Ratnagiri

Copy s.w.r. to: The Superintending Engineer, EHV O&M Circle, Kolhapur.

Copy to: Dy. Manager (F&A) EHV O&M Division, Ratnagiri / Notice Board.



MAHARASHTRA STATE ELECTRICITY TRANSMISSION CO. LTD.
EHV O&M DIVISION, RATNAGIRI

Name of Work - Providing of gantry structure for 100MVA, 220/132 kV ICT at 220 kV Kharepatan S/s, under EHV O&M Dn., Ratnagiri.

SCHEDULE 'A'

Sr. No.	Particulars	Unit	Qty.	Unit Rate (Rs.) Incl. all taxes	Quote Rates in % Basis (At Par/ Above/ Below)
1	Supply of Gantry structure at 220kV Kharepatan S/s. Beam type B9-1No & Column type T9x-1No. (Drawing attached)	MT	As per actual	108266.61	

The total value of order is limited up to **Rs. 3.0 Lakhs** (Rs. Three Lakhs Only) including of all taxes.

- Note:-**
- 1) Please quote Rate in percentage (%) basis only.
 - 2) Please see conditions before quoting rates.
 - 3) Rates are inclusive of GST.
 - 4) Before quoting the rates the contractor may visit the site location.
 - 5) Taxes if any should be quoted separately otherwise it will be presumed that the rates are inclusive of all taxes.

sd/-
(Vijaykumar A. Nikam)
Executive Engineer
EHV O&M Dn., MSETCL,
Ratnagiri

Sub: Bidders Debarred/ Blacklisted by Government/ Semi-Government/Other Power Utilities --- Prohibiting participation of such Firms in MSETCL Tenders

ANNEXURE-G

Undertaking to be submitted by the Bidder declaring that Bidder is not Debarred/ Blacklisted by Government/ Semi-Government/Other Power Utilities

I/We hereby declare that I/We is/are participating in MSETCL's Enquiry

As on date of submission of this Tender, I/We hereby declare that My Firm/We is/are not Debarred/ Blacklisted by Any Government/ Semi-Government/Other Power Utilities, anywhere.

The above declaration is true to the best of My/Our knowledge and belief.

I/We hereby agree that in case My Firm/We are Debarred/ Blacklisted by Any Government/ Semi- Government/Other Power Utilities, anywhere, My/Our Offer is liable for rejection at any stage of Tendering process as per Tender Conditions.

Further, I/We hereby understand and agree that in case My Firm/We are Debarred/ Blacklisted by Any Government/ Semi-Government/Other Power Utilities, anywhere, My/Our order is liable for termination at any stage of Order execution process and My Firm/We shall be solely responsible for the consequences arising out of it.

Signature & seal of the Tenderer

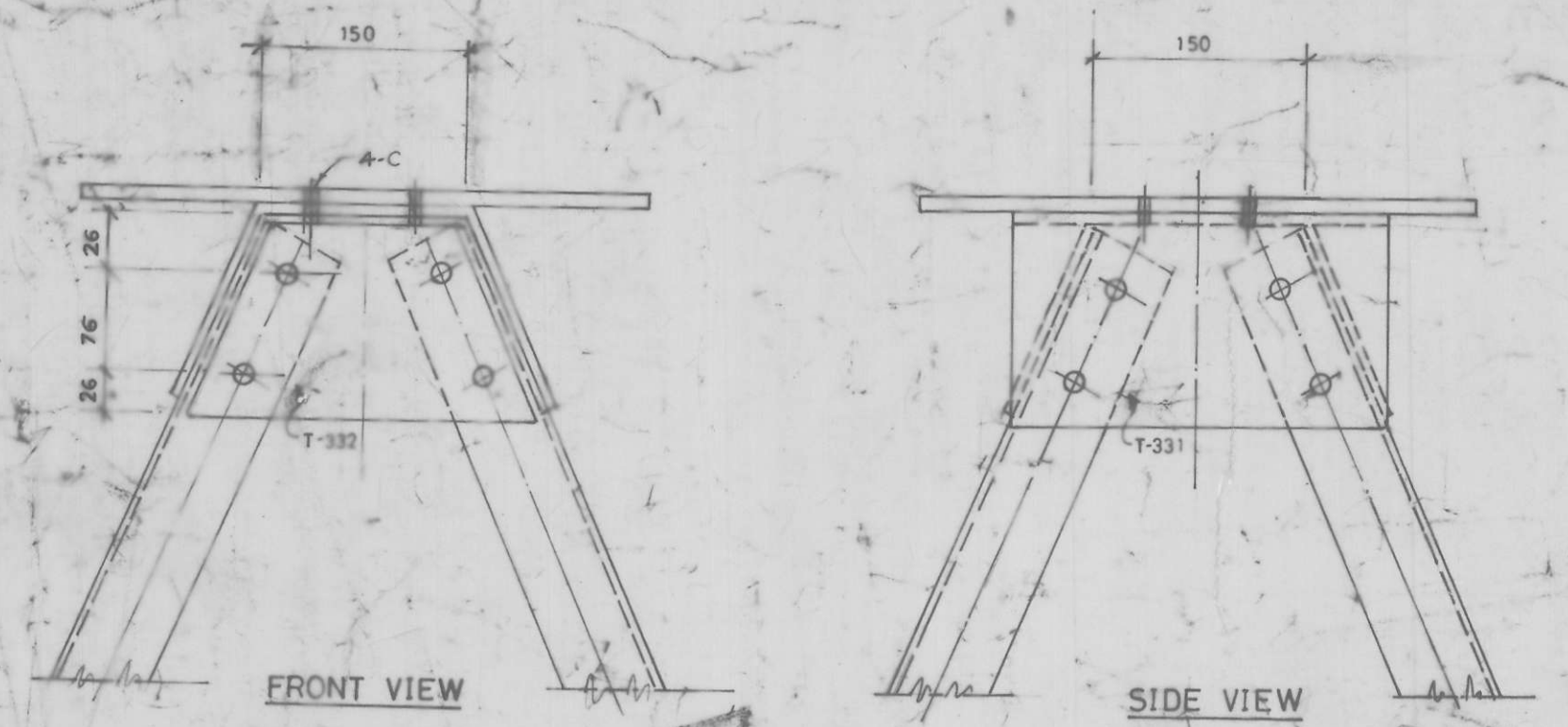
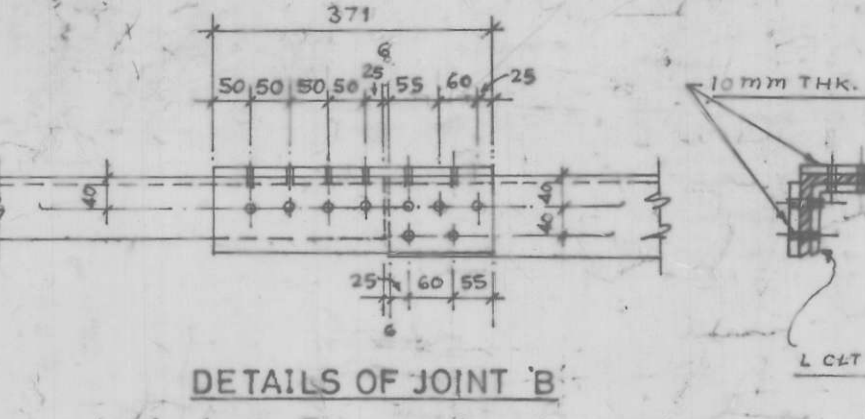
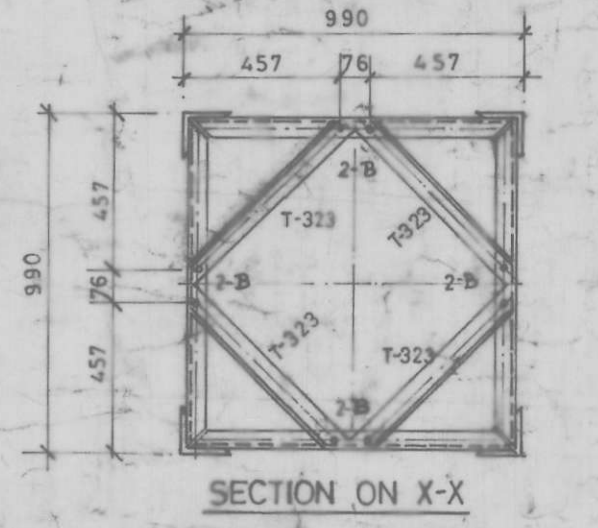
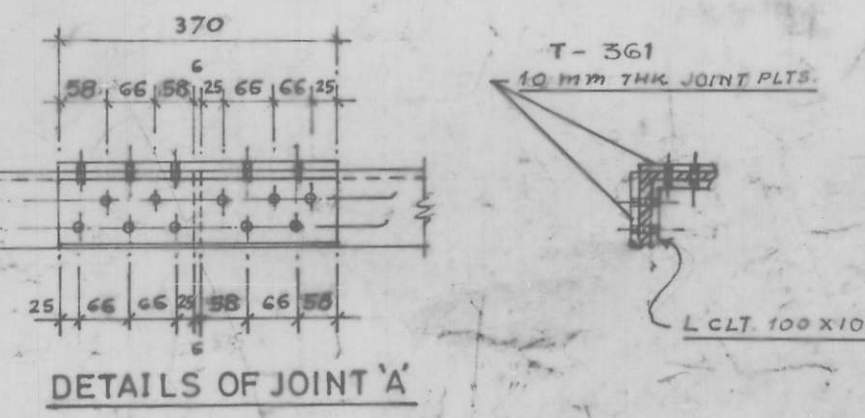
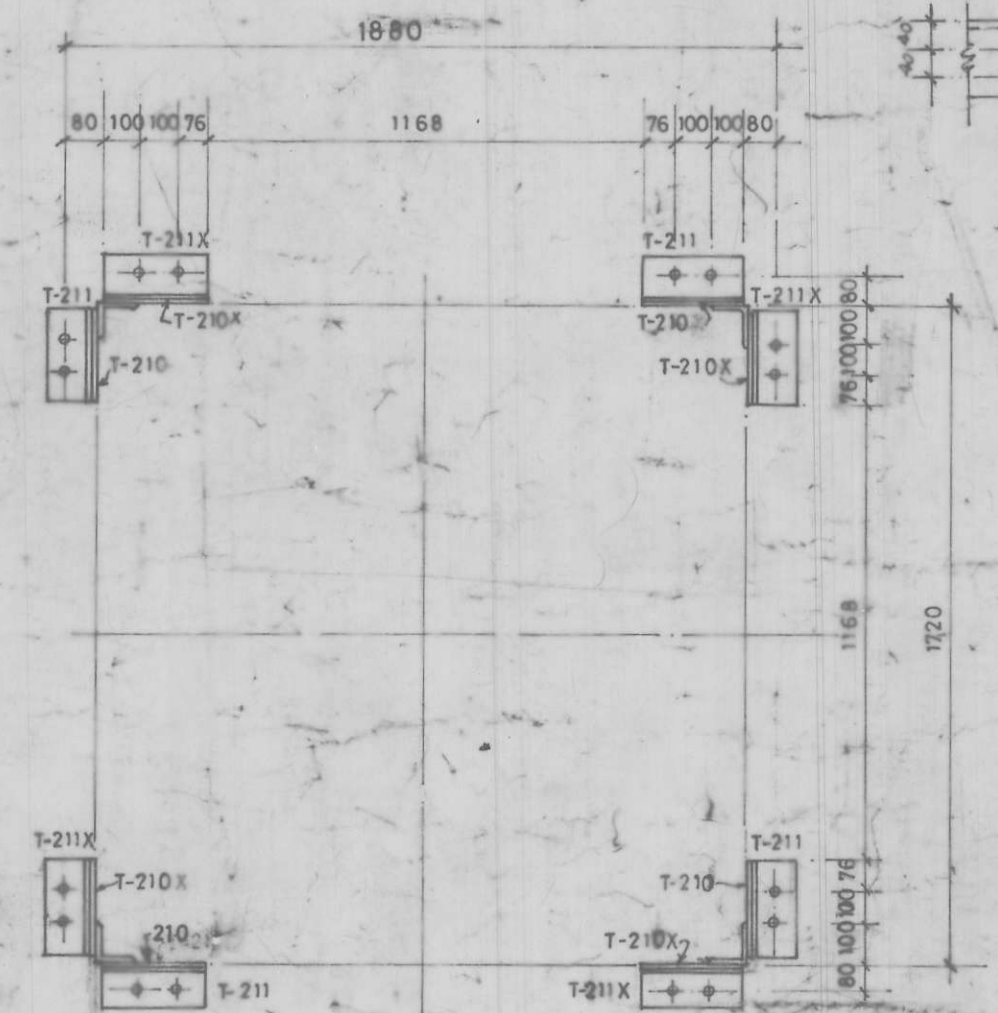
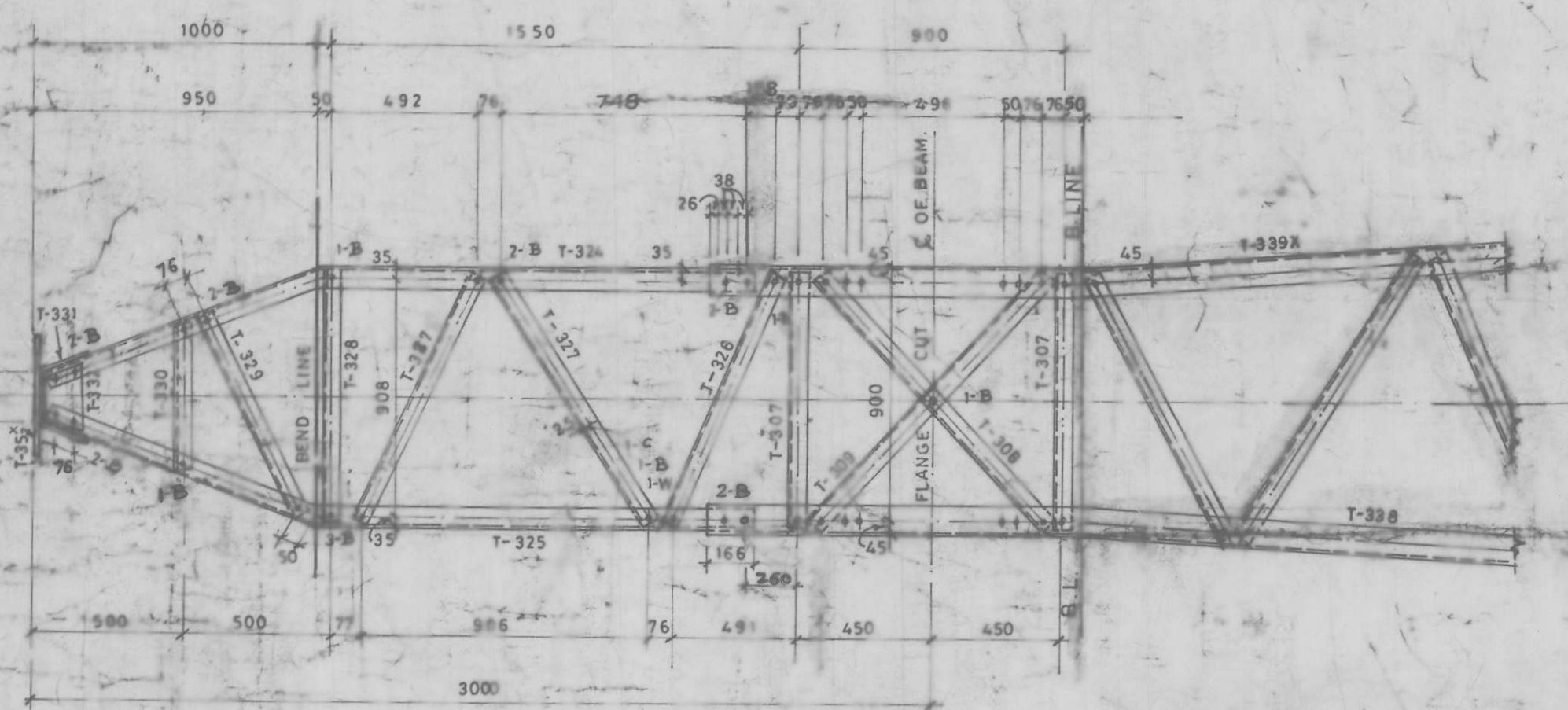
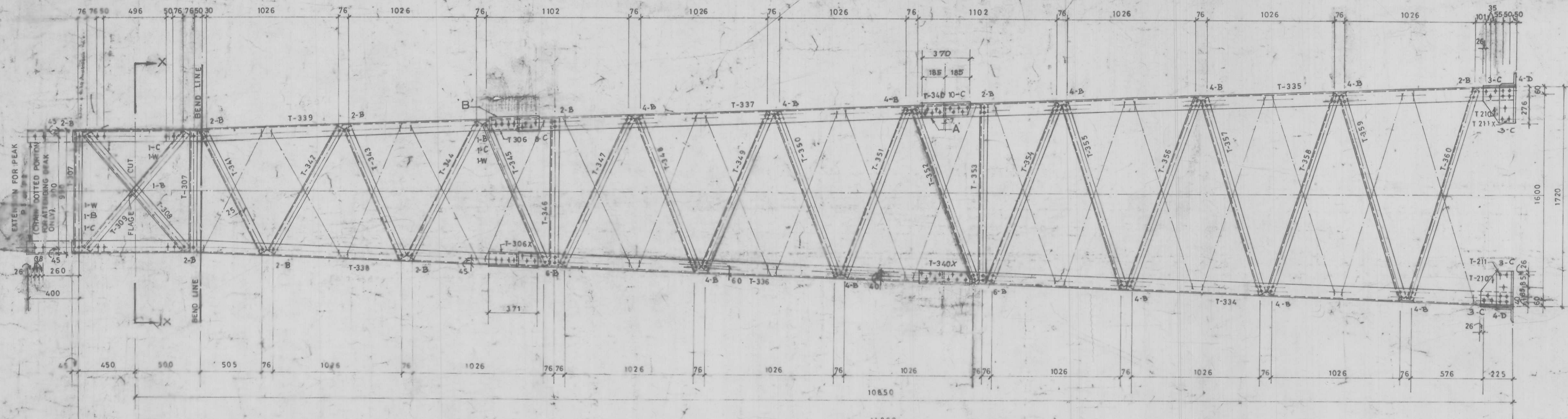

DETAIL AT 'A'

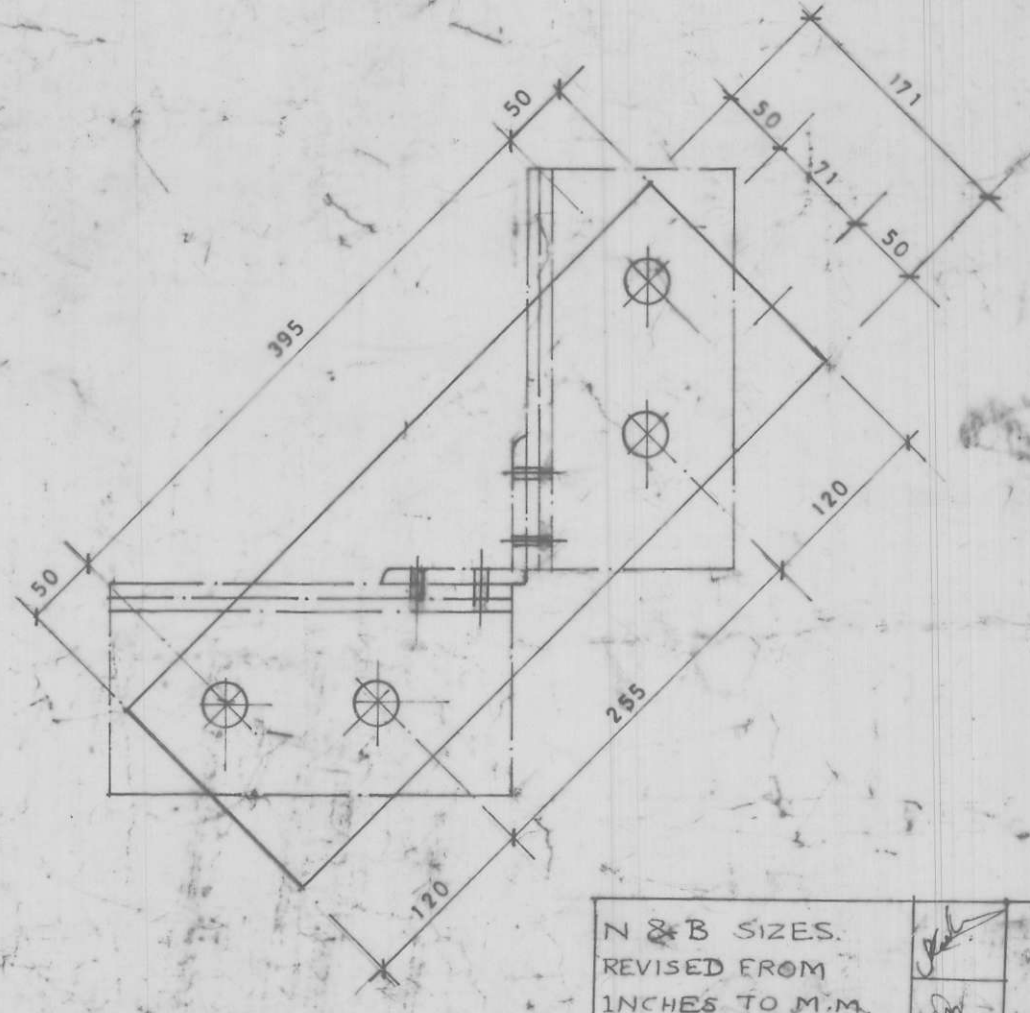
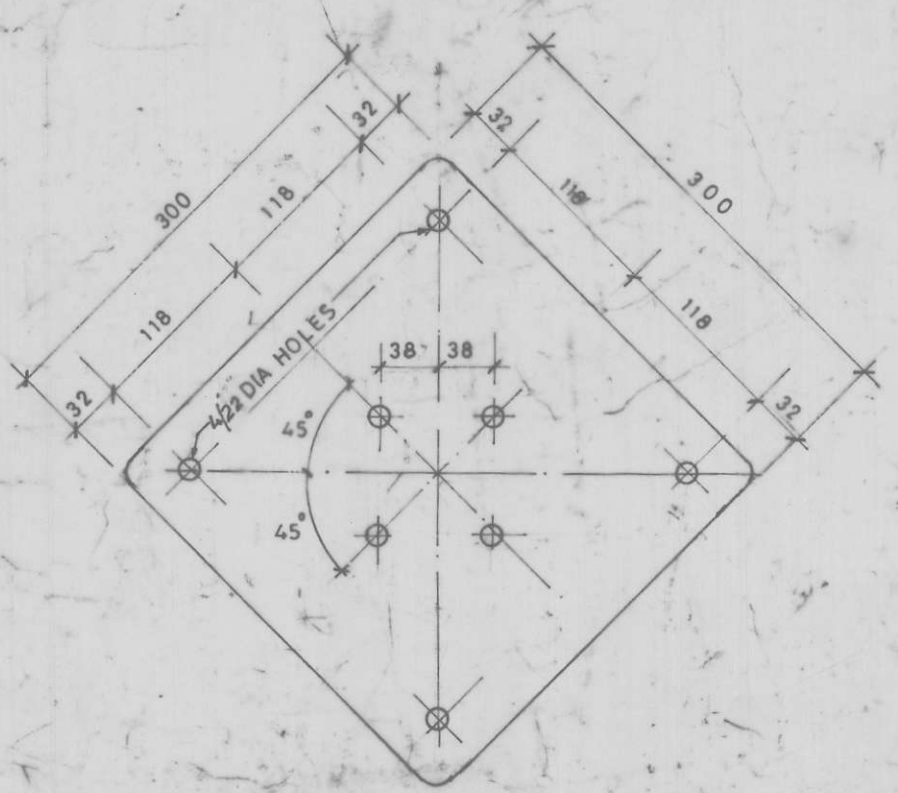

N & B SIZES.
REVISED FROM
INCHES TO M.M.

ITEM No-361
INCORPORATED
AS PER CENTRY.

DATE-20-4-89
REV'D
DATE-12-7-78
REV 'A'

- NOTES-
1. ALL DIMENSIONS ARE IN MILLIMETER UNLESS OTHERWISE SPECIFIED.
 2. ALL HOLES ARE 1/16" UNLESS OTHERWISE STATED.
 3. REF. DRG. NO. 06-055 FOR DETAILS OF TOWER ACCESSORIES.
 4. FOR GIRDER DETAILS REFER DRG. NO. 06-140

ERECTION MARK	DISCRPTION	QTY.	
		T-9	T-9X
T-334	100 X 100 X 10 L	2	2
T-335	-DO-	2	2
T-336	-DO-	2	2
T-337	-DO-	2	2
T-338	80 X 80 X 6 L	2	2
T-339	-DO-	2	2
T-339X	-DO-	2	2
T-306	100 X 100 X 10 L JOINT PIECES	4	2
T-340	-DO-	4	2
T-340X	-DO-	4	2
T-341	50 X 50 X 6 L	4	4
T-342	-DO-	4	4
T-343	-DO-	4	4
T-344	-DO-	4	4
T-345	-DO-	4	4
T-346	-DO-	4	4
T-347	-DO-	4	4
T-348	-DO-	4	4
T-349	-DO-	4	4
T-350	-DO-	4	4
T-351	-DO-	4	4
T-352	-DO-	4	4
T-353	-DO-	4	4
T-354	-DO-	4	4
T-355	-DO-	4	4
T-356	-DO-	4	4
T-357	-DO-	4	4
T-358	-DO-	4	4
T-359	-DO-	4	4
T-360	50 X 50 X 6 L	4	4
T-307	50 X 50 X 5 L	4	4
T-308	DO	4	4
T-309	DO	4	4
T-323	DO	8	8
T-210	10 MM THICK GUSSET PLATE	4	4
T-210X	10 MM THICK GUSSET PLATE	4	4
T-211	130 X 130 X 10 L BASE CLEAT	4	4
T-211X	130 X 130 X 10 L BASE CLEAT	4	4
T-324	65 X 65 X 6 L	2	2
T-325	DO	2	2
T-326	50 X 50 X 5 L	4	4
T-327	DO	4	4
T-328	DO	4	4
T-329	DO	4	4
T-330	DO	4	4
T-331	8 MM THICK BEND PLATE	1	1
T-332	8 MM THICK GUSSET PLATE	2	2
T-35X	10 MM THICK 'STRAIN' PLATE	1	1
T-34X	10 MM THICK FOUNDATION PLATE	4	4
FOUNDATION BOLT AS PER DRG. NO. 06-256		16	16
M16 X 40 LONG BOLTS & NUTS		356	436
M16 X 45 LONG BOLTS & NUTS		172	176
M16 X 55 LONG BOLTS & NUTS		32	32
3/8" THICK SPRING WASHERS FOR 5/8" Ø BOLTS		560	644
6mm THICK PACK WASHERS FOR 5/8" Ø BOLTS		16	16
T-361	10 M.M. THK. COVER PLATE	1	8

MAHARASHTRA STATE ELECTRICITY BOARD
PLANNING SECTION

TOWER TYPE T-9 & T-9X

DRAWN: [Signature] CHECKED: [Signature] APPROVED: [Signature]

SCALE: 1:20 BOMBAY DRG. NO. 06-041C
DATE: 20-8-1976

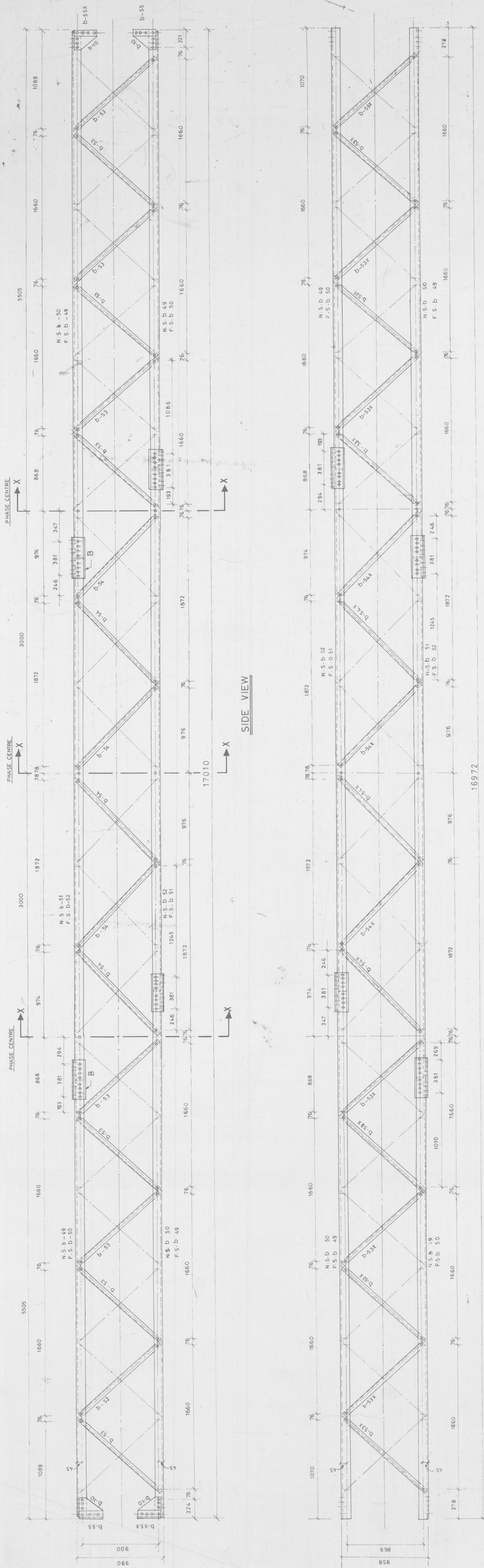

TOP & BOTTOM PLAN

SIDE VIEW

ERECTION MARK	DESCRIPTION	QTY
b-49	80 X 80 X 8L	4
b-50	80 X 80 X 8L	4
b-51	80 X 80 X 8L	7
b-52	80 X 80 X 8L	7
b-53	50 X 50 X 5L	24
b-53A	50 X 50 X 5L	24
b-54	50 X 50 X 5L	12
b-54A	50 X 50 X 5L	12
b-55	80 X 80 X 8L	4
b-55A	80 X 80 X 8L	4
b-56	8 mm THK COVER PLATE	16
b-57	80 X 80 X 8L	6
b-58	50 X 50 X 5L	6
b-59	65 X 65 X 6L	3
b-19	65 X 65 X 6L	3
b-60	50 X 50 X 5L	3
b-61	50 X 50 X 5L	3
b-61X	50 X 50 X 5L	3
D-10	8 mm THK GUSSET PLATE	8
b-22	20mm DIA U BOLTS WITH WASHERS	3
	M14-45mm LONG BOLTS WITH NUTS	136
	M16-40mm LONG BOLTS WITH NUTS	269
	3.5 THK SPRING WASHERS	405
	6.5 THK RACK WASHERS	6

MATERIAL LIST

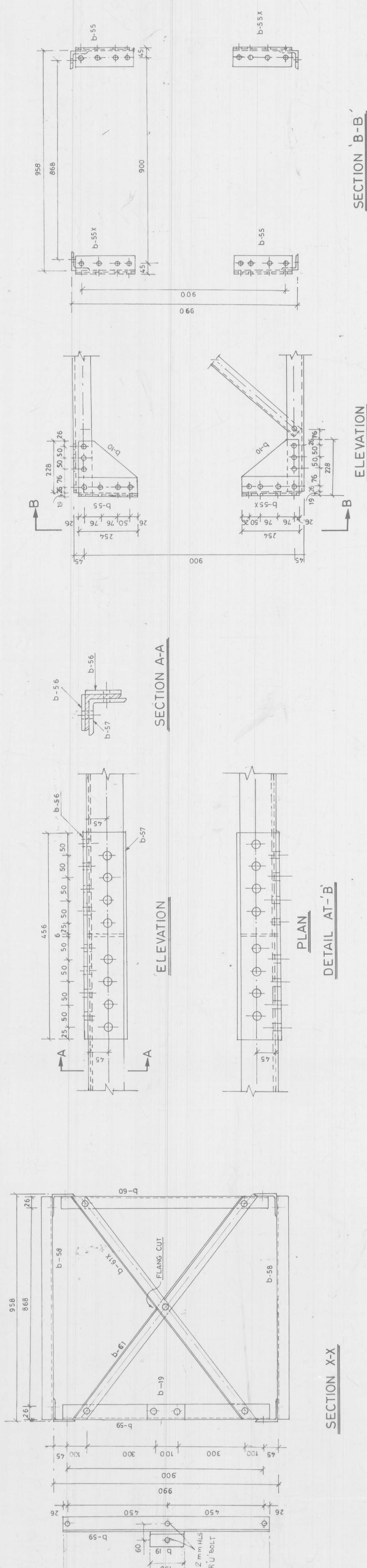

DETAILS OF GIRDER END CONNECTION

- NOTES—
- 1) ALL DIMENSIONS ARE IN MM UNLESS OTHERWISE SPECIFIED.
 - 2) ALL HOLES ARE OF 17.5 DIA. UNLESS OTHERWISE STATED.
 - 3) NO HOLES TO BE KEPT OPEN.
 - 4) FOR TOWER DETAILS REFER DRG. NO. 06.041A.

DETAILS OF GUSSET PLATE

DETAILS OF U-BOLT

DATE: 29.4.89
REV: 3
SCALE: 1:20
N.B. SIZES REVISED FROM INCHES TO MM